

REV.	MODIFICATION.	DATE	DRN
1 02	Sales Print CO-2010462	07/10/08 03/11/08	PH OW

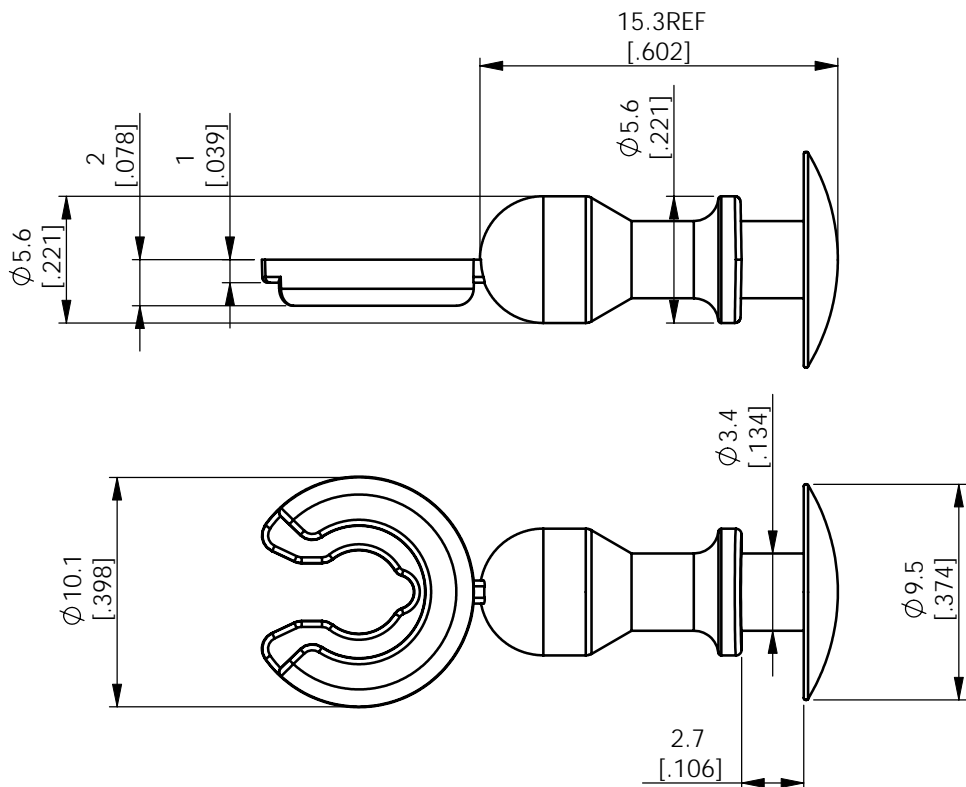

Assembly Method

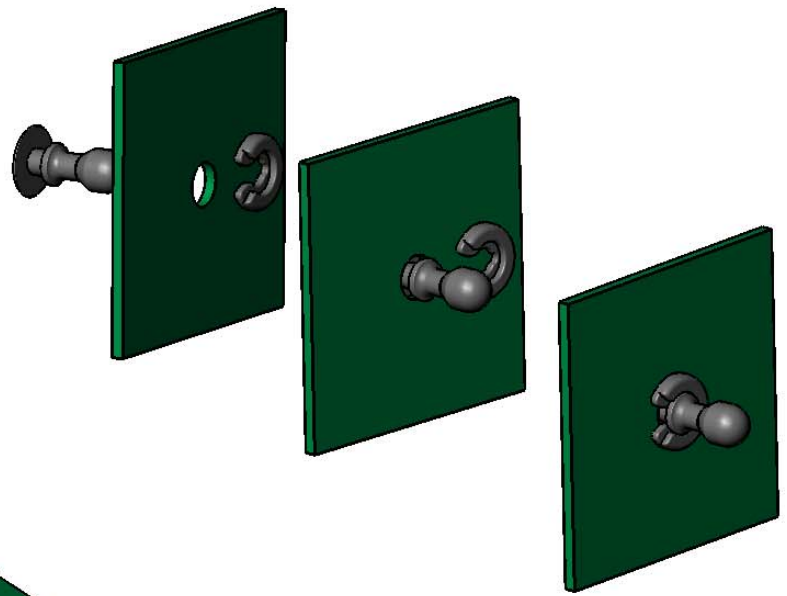

TO FIT A Ø5.8 - 6.4 HOLE,
INTO A 1.6 THICK PANEL.
TO MATE WITH PART CS113-X

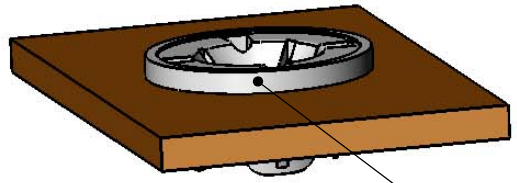
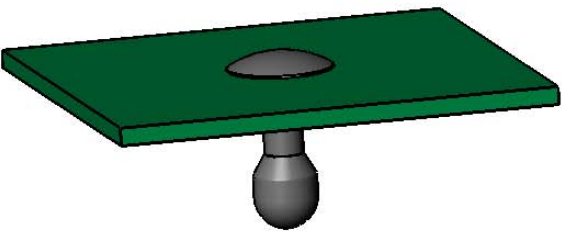

Accommodates with CS-113-1 and CS-113-4 Catch

- NOTES:
1a) METRIC PRIMARY UNITS:mm
1b) IMPERIAL SECONDARY UNITS:[inches]

INFORMATION CONTAINED IN THIS DOCUMENT IS CONFIDENTIAL TO RICHCO INTERNATIONAL Co. Ltd. AND MAY NOT BE DISCLOSED OR REPRODUCED IN WHOLE OR PART WITHOUT THEIR WRITTEN CONSENT.

	GENERAL TOLERANCES ±0.25 [0.010] UNLESS OTHERWISE STATED 1 DECIMAL PLACE ±0.25 [0.010] 2 DECIMAL PLACES ±0.10 [0.004] ANGULAR ±1°	THIRD ANGLE

MATERIAL: NYLON 6/6 IMPACT MODIFIED (RMS 148)	COLOUR: BLACK
--------------------------------------------------	------------------

DESCRIPTION: SNAP IN STRIKER	PART No: CS-113-6
---------------------------------	----------------------

DRG No: 08-103	NPR No: GB08-0049	Mass:(g) 0.5	SHEET SIZE A4
-------------------	----------------------	-----------------	------------------

DRN PH	DATE 19/12/07	CHKD TC	DATE 10.6.08	SCALE NTS	SHEET No. 1 OF 1
-----------	------------------	------------	-----------------	--------------	---------------------