

PC BOARD HOLE LOCATION

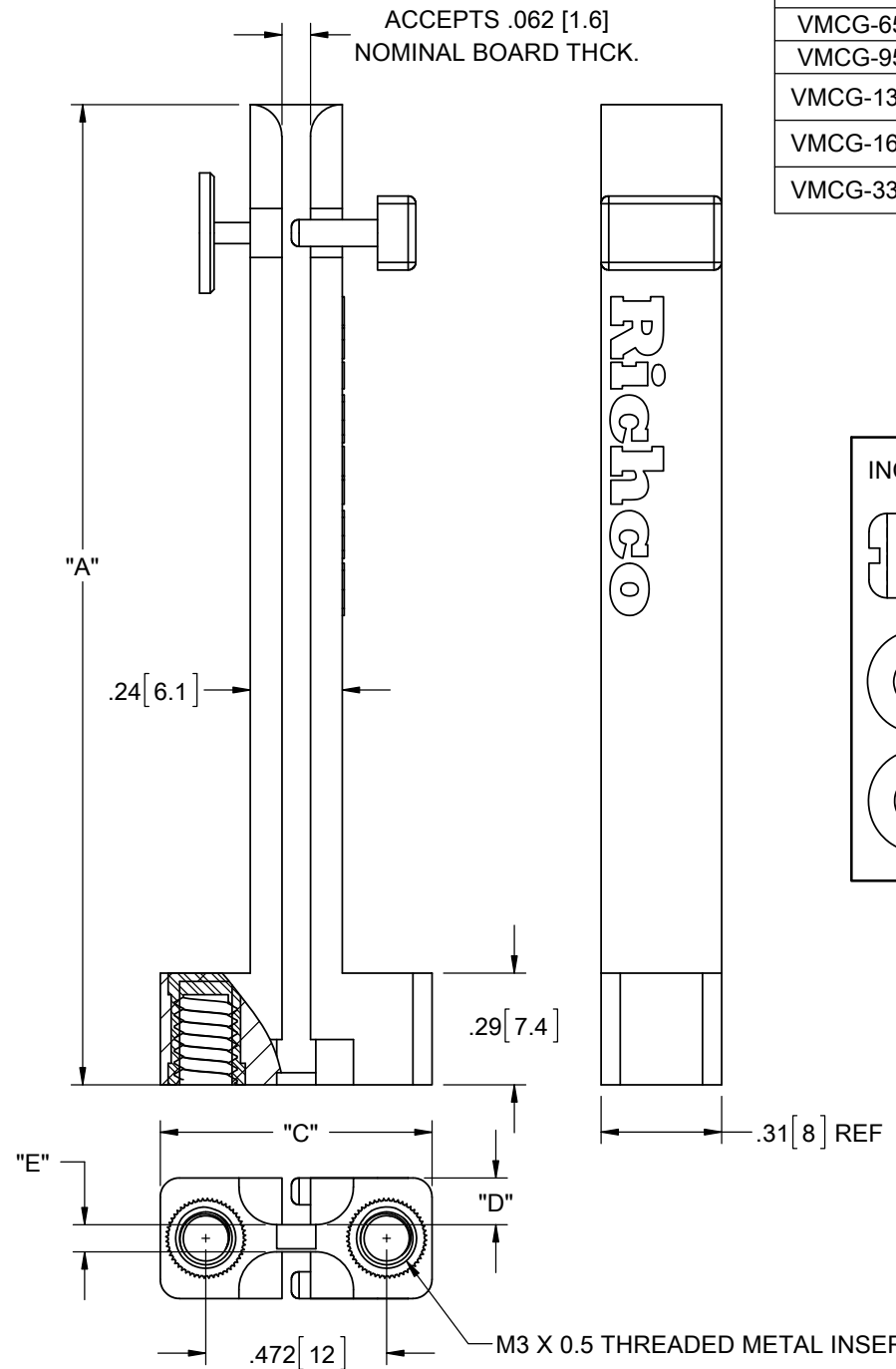

PART NO.	"A"	"B"	"C"	"D"	"E"
VMCG-50-MPBK-K	1.83 [46.5]	1.67 [42.3]	.71 [18]	.104 [2.6]	.105 [2.7]
VMCG-65-MPBK-K	2.56 [65]	2.22 [56.5]			
VMCG-95-MPBK-K	3.54 [90]	3.21 [81.5]			
VMCG-135-MPBK-K	5.31 [135]	4.98 [126.5]	.75 [19]	.118 [3]	.079 [2]
VMCG-160-MPBK-K	6.30 [160]	4.43 [112.5]	.71 [18]		
VMCG-330-MPBK-K	4.73 [120.1]				

INCLUDED HARDWARE	
	X2
	X2
	X2

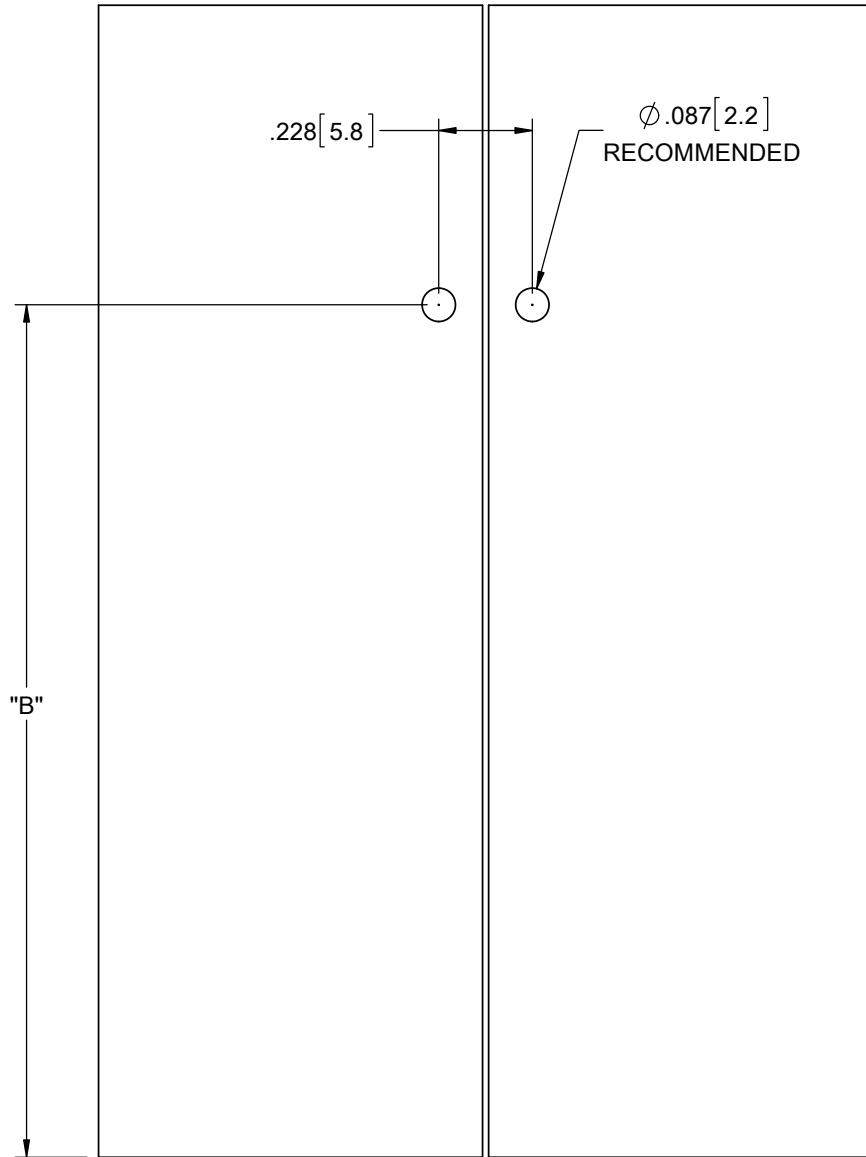
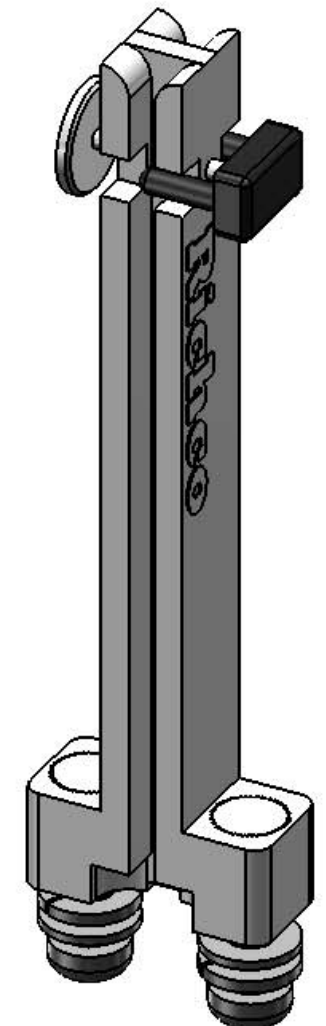

NOTES:

- STANDARD MATERIAL: NYLON 6, GLASS FILLED (RMS-38). COLOR: GRAY.  
ALTERNATE MATERIAL: NYLON 6 UL94 V-0 (RMS-371). AVAILABLE BY SPECIAL ORDER.  
TO ORDER USE P/N: VMCG-XX-MPBK-FR-K.COLOR: GRAY.
- COMPONENTS:
  - LOCKING BUTTON: HDPE (RMS-284)
  - SCREW: MILD STEEL, ZINC PLATED (RMS-415)
  - THREADED INSERT: BRASS (RMS-231)
  - WASHER: STAINLESS STEEL (RMS-228)

REV.	DESCRIPTION	ENGR.	DATE
0	REDRAWN, SEE CO 200749	SK	01/18/2012
-	SEE ENGINEERING FOR REV A-N	--	-----

TITLE: VERTICAL MOUNT CARD GUIDE, TYPE 1				UNITS: IN [MM]		FINAL	
CREATED USING SOLIDWORKS	FILE #: VMCG-1	DWN: SK	APP: SK	PART #			
TOLERANCES UNLESS NOTED .XX=±.010 .XXX=±.005 FRAC.=±1/64 ANG.=±1°	SHEET: 1 OF 1	SHEET SIZE: B	DT: 11/11/11	CHKD: DZ	SEE TABLE		PRINT TYPE
RE: RICHCO, INC.		RICHCO, INC. WWW.RICHCO-INC.COM				CA	